



# C.T.M. MOBILITY SCOOTER

5-Series Instruction Booklet



HS-570



HS-580

# TABLE OF CONTENTS

INTRODUCTION .....	1
IMPORTANT PRECAUTIONS .....	2
ELECTROMAGNETIC INTERFERENCE AND WARNINGS .....	3
IDENTIFICATION OF PARTS .....	5
OPERATING YOUR SCOOTER .....	7
DISASSEMBLING YOUR SCOOTER .....	9
ASSEMBLING YOUR SCOOTER .....	11
CHARGING THE BATTERIES .....	12
CARE AND MAINTENANCE .....	13
TROUBLESHOOTING .....	14
TECHNICAL SPECIFICATIONS .....	16

## INTRODUCTION

Thank you and congratulations on purchasing your new C.T.M. Mobility Scooter. It is designed to provide you with transportation indoors and outdoors.

We pride ourselves on providing safe and comfortable products. Our goal is to ensure your complete satisfaction with our product. We are certain that you will enjoy your C.T.M. mobility scooter.

Please read and observe all warnings and instructions given in the owner's manual before operating this scooter. Also, retain this booklet for future reference.

**If you have any questions, you can contact:**

**C.T.M.HOMECARE PRODUCT, INC.**

6191 Schaefer Ave Suite B Chino CA 91710

Tel : +909-590-1388 Fax : +909-590-3365

E-Mail : [ctm@ctmhomecare.com](mailto:ctm@ctmhomecare.com) [http : //www.ctmhomecare.com](http://www.ctmhomecare.com)

**or your local dealer:**

## IMPORTANT PRECAUTIONS

Only one person at a time can ride a C.T.M. Mobility Scooter.

Maximum load is 135 kg/300 pounds.

Turn key off before getting on or off.

Always drive carefully and be aware of others using the same area as yourself.

Always use pedestrian crossings where possible. Take extreme care crossing roads.

Do not drive on slopes exceeding a 1 in 4, and take extreme care when turning on slopes.

Do not use full power when turning sharp corners.

Take great care and use low speeds for backing up, downhill, uneven surfaces, and curb climbing.

Scooter may not operate well in high humidity.

If you are caught in the rain, it is handy to carry a scooter canopy. This can offer complete protection for yourself and the scooter.

Never put scooter in neutral on slopes.

Follow traffic laws when you ride outside.

## ELECTROMAGNETIC INTERFERENCE AND WARNINGS

**CAUTION: It is very important that you read this information regarding the possible effects of Electromagnetic Interference on your motorized scooter.**

Powered wheelchairs and motorized scooters may be susceptible to electromagnetic interference (EMI), which is interfering electromagnetic energy (EM) emitted from sources such as radio stations, TV stations, amateur radio (HAM) transmitters, two-way radios, and cellular phones. The interference (from radio wave sources) can cause the motorized scooter to release its brakes, move by itself, or move in unintended directions. It can also permanently damage the motorized scooter control system. The intensity of the interfering EM energy can be measured in volts per meter (V/m). Each motorized scooter can resist EMI up to certain intensity. This is called its "immunity level." The higher the immunity level, the greater the protection. At this time, current technology is capable of achieving at least a 20 V/m immunity level, which would provide useful protection from the more common sources of radiated EMI. This immunity level of this motorized scooter model is not known.

There are a number of sources of relatively intense electromagnetic fields in the everyday environment. Some of these sources are obvious and easy to avoid. Others are not apparent and exposure is unavoidable. However, we believe that by following the warnings listed below, your risk to EMI will be minimized.

**The sources of radiated EMI can be broadly classified into three types :**

1. Hand-held portable transceivers (transmitters-receivers) with the antenna mounted directly on the transmitting unit. Examples include: citizens band (CB) radios, "walkie talkie," security, fire, and police transceivers, cellular telephones, and other personal communication devices;



**Some cellular telephones and similar devices transmit signals while they are ON, even when not being used.**

2. Medium-range mobile transceivers, such as those used in police cars, fire trucks, ambulances, and taxis. These usually have the antenna mounted on the outside of the vehicle; and
3. Long-range transmitters and transceivers such as commercial broadcast transmitters (radio and TV broadcast antenna towers) and amateur (HAM) radios.



**Other types of hand-held devices, such as cordless phones, laptop computers, AM/FM radios, TV sets, CD players, and cassette players, and small appliances, such as electric shavers and hair dryers, so far as we know, are not likely to cause EMI problems to your motorized scooter.**

**Motorized Scooter Electromagnetic Interference :**

Because EM energy rapidly becomes more intense as one moves closer to the transmitting antenna (source), the EM fields from hand-held radio wave sources (transceivers) are of special concern. It is possible to unintentionally bring high levels of EM energy very close to the motorized scooter control system while using these devices. This can affect motorized scooter movement and braking. Therefore, the warnings listed below are recommended to prevent possible interference with the control system of the motorized scooter.

**Warnings :**

Electromagnetic interference (EMI) from sources such as radio and TV stations, amateur radio (HAM) transmitters, two-way radios, and cellular phones can affect motorized scooters. Following the warnings listed below should reduce the chance of unintended brake release or motorized scooter movement which could result in serious injury.

1. Do not operate hand-held transceivers (transmitters-receivers), such as citizens band (CB) radios, or turn ON personal communication devices, such as cellular phones, while the motorized scooter is turned ON;
2. Be aware of nearby transmitters, such as radio or TV stations, and try to avoid coming close to them;
3. If unintended movement or brake release occurs, turn the motorized scooter OFF as soon as it is safe;
4. Be aware that adding accessories or components, or modifying the motorized scooter, may make it more susceptible to EMI; and



There is no easy way to evaluate their effect on the overall immunity of the motorized scooter.

5. Report all incidents of unintended movement or brake release to the distributor listed on the inside front cover of this manual. Note whether there is a source of EMI nearby.

**Important Information :**

1. 20 volts per meter (V/m) is a generally achievable and useful immunity level against EMI (as of May 1994). The higher the level, the greater the protection.
2. This product has an immunity level of at least 10 V/m.

## IDENTIFICATION OF PARTS

Before attempting to drive this scooter on your own, it is important that you familiarize yourself with the controls, and how to operate



Figure 1 - HS-580 Front View



Figure 2 - HS-580 Control Panel



Figure 3 - HS-580 Rear View

**FUNCTION OF PARTS :****TOP CONTROL PANEL**

## Speed Control Knob

The Rabbit means fast and Turtle is slow. By turning this you control the total speed transferred to the thumb controls.

## Self Diagnostic Warning Light

Flashing indicates problems with the scooter. See page 15 for more information.

## Battery Gauge

This light is yellow. Below it are three color ranges: red, yellow and green. When the light is on in all three color ranges, the batteries are fully charged. When the light is on only in the red, or red and yellow areas, the batteries need to be recharged.

**BENEATH TOP CONTROL PANEL**

## Thumb Levers

Pushing the right thumb lever moves the scooter forward. Pushing the left thumb lever moves the scooter backward. (This can be reversed if required by local dealer.) Releasing both engages the automatic brake. This is also your accelerator. The further you depress them, the faster you go. (Subject to the position of the Rabbit/Turtle control).

**AT BASE OF STEERING TILLER**

## Steering Column Lever

Push downward on the handle to adjust. Pull up to lock Steering Column at comfortable angle.

**BELOW SEAT**

## Seat Control Levers

Seat Control Slide - Lift up on lever under front edge of seat to adjust forward and backward. Seat Rotation Lever - Push lever back to rotate seat; push forward to lock seat in position.

## Thumbscrews

Loosen the two Thumbscrews to adjust the arm width; tighten again to lock the desired position.

**REAR BODY**

## Rear Cover

Protects batteries from damage.

## Anti-tip wheels

Helps keep the scooter from tipping over.

## Free-Wheeling Lever

When lever is in the N (Neutral) position, the scooter can be moved without power.

When lever is in the D (Drive) position, the scooter can be driven. Normal position is D.

## Storage area

This is situated above the rear bumper.

## OPERATING YOUR SCOOTER

You can make the following adjustments to increase your comfort when driving.

adjust seat height and location

adjust steering column to comfortable position.

adjust legroom.

1. Before operating your scooter, check the following:

free-wheeling device on D

speed dial is at the turtle picture.

2. Sit on scooter and turn on key. The Battery Gauge light should be lit in the green, yellow, and red color zones. The Self-Diagnostic Warning Light should not be blinking.

3. When your hands rest comfortably on the handlebars, the thumb control levers should be within easy reach. The right lever moves the scooter forward, the left one moves it backward. When you release both levers the scooter will stop.



This scooter has automatic braking systems. Release the thumb finger control and the brakes will stop the scooter.

4. Steer the scooter by turning the whole steering column the way you want to go.

5. Practice driving where there are no obstacles. Start at the slowest speed and drive forward and backward; make some turns. As you get more comfortable you can increase the speed by turning the speed dial toward the picture of the rabbit.

6. If two Battery Gauge LED Lights be lit, you should plan to recharge the batteries very soon.

7. If the scooter stops, locate the circuit breaker on the top of the battery pack. Push it and try the scooter again.

8. When you are finished riding, turn off the key before getting off.

9. If you are finished riding for the day, immediately recharge the batteries.

See CHARGING THE BATTERIES, page 14 and 15.

**Keep in mind these rules :**

Release thumb levers and allow scooter to stop completely before changing from forward to reverse, or reverse to forward.

When turning a corner, swing the front wheels wide, because the back wheels will turn more tightly.

Use the scooter only where it would be safe to walk.

Use low speeds for reverse, downhills, ramps, curbs, or uneven surfaces.

**Other Operating Information :**

Hill climbing: You may need to use a higher speed. Turn to lower speed before going downhill.

Down slopes: To proceed down steep slopes slowly, set speed control in proximity of the turtle. This enables driver control, as the closer the speed control is set toward the turtle, the slower it will become. However, this scooter will not self accelerate down hills due to the automatic braking taking effect should you attempt to drive too fast.

Curb climbing: Approach slowly at right angles to the Curb. A slight angle is permissible with a 4-wheel scooter, but a direct approach is needed on a 3-wheel scooter. Do not attempt greater than a 4" curb.

If Self-Diagnostic Warning Light starts to blink, identify the problem from the chart on page 15 and take action.

If the scooter breaks down and must be moved, get off the scooter, push the Free-Wheeling Lever to N, move the scooter slowly to a safe location, and move the lever back to D.

**DISASSEMBLING YOUR SCOOTER**

No tools are necessary. You can disassemble scooter for transport.

Remove seat by releasing Seat Rotation Lever(A)and then lift off. (See Fig. 4)  
gently lift rear storage cover (B). (See Fig. 5)

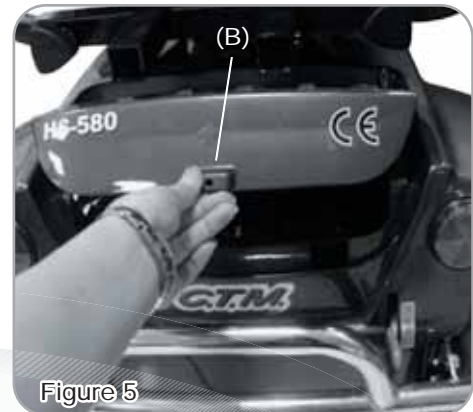
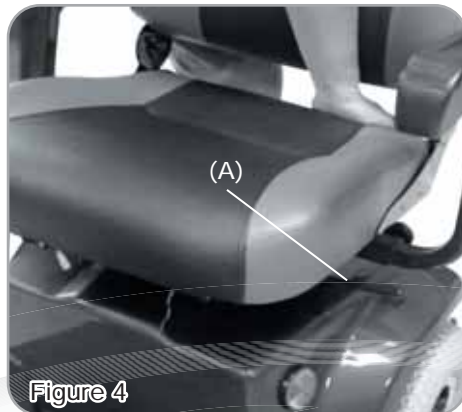

Unscrew controller wiring harnesses (C). (See Fig. 6)  
Remove rear shroud off of the scooter (D). (See Fig. 7)

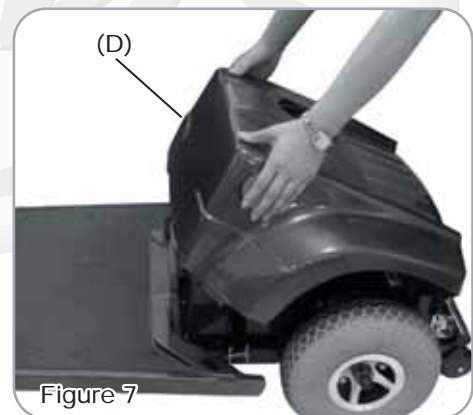

Remove battery fixing Velcro (E). (See Fig. 8)  
Unplug both battery harnesses (F) and remove batteries (G). (See Fig. 9)

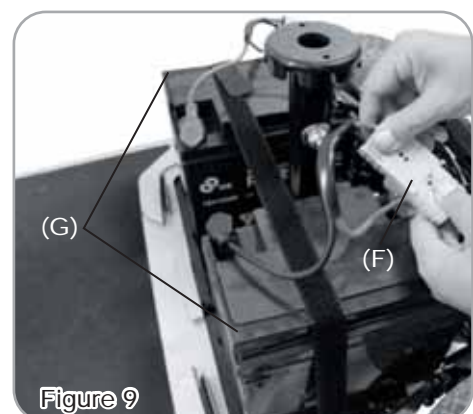
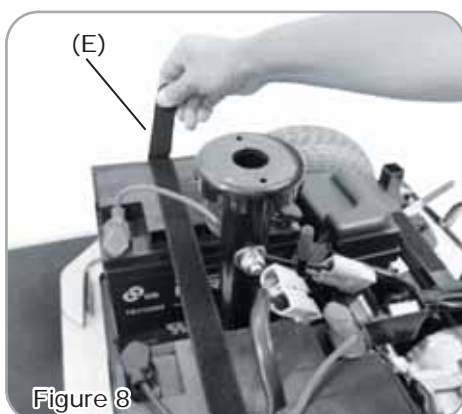

Detach the front and rear sections by holding the Seat Post (J) with one hand and the other hand pushing the release lever to the rear of the scooter. Lift the seat post to separate the Rear Frame Assembly (H) from the Front Frame Assembly. (See Fig. 10 & 11)

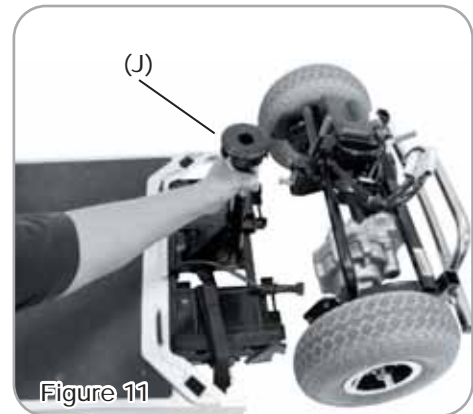
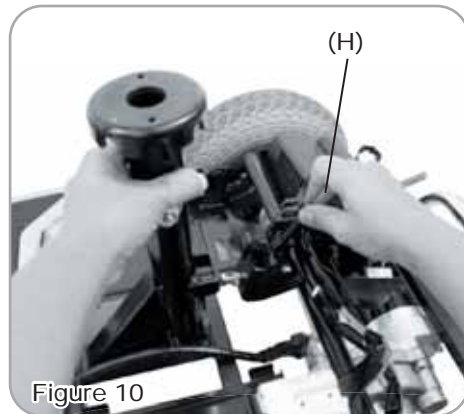

By removing the front basket (K) and adjusting the tiller down by using the Steering Column Lever (L), you should be able to place all parts in the boot and part of the rear seat. (See Fig. 12)

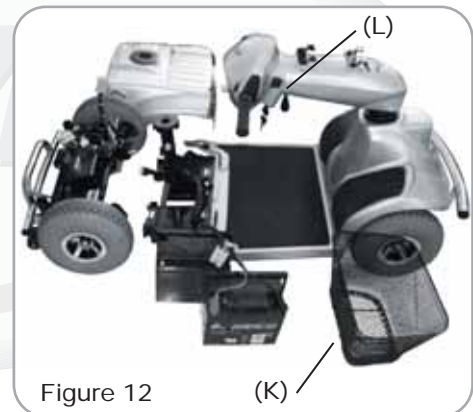

## ASSEMBLING YOUR SCOOTER

**To assemble the scooter, you can repeat the disassembly directions in reverse. Abbreviated directions are given below. Refer to the Figures on pages 11 - 12 to locate the parts.**

1. Use the Steering Column Lever to move the Steering Column up out of the way.
2. Tilting the rear end to a horizontal position, insert the scooter frame tube of the front end into the rear section first, making sure that the locking pins are removed.
3. Slide the two sections of the unit together until the front half reaches its limit.
4. Insert the two locking pins into their corresponding holes. Both locking pins must be fully inserted whenever the scooter is assembled.
5. Place batteries, use Velcro to fix the position and attach the battery power plugs.
6. Place rear shroud.
7. Screw together controller wiring harness.
8. Place rear storage cover.
9. Loosen Seat Rotation Lever counterclockwise. Place seat on seat post. Tighten Lever again by turning clockwise. Lock Seat Control Lever on bottom of seat before sitting down.

## CHARGING THE BATTERIES

Batteries must be charged before using the scooter for the first time and should be recharged after each day use. You will need the scooter and the battery charger.



Each country may supply different charger. The charging procedure may be different from below.

If you require more details, please contact your authorized dealer.



Be sure the scooter key is in the OFF position



1. Insert battery charger cord into the charger connector on the charger output. Refer to above figure for correct position
2. Plug the other end of the battery charger cable into a standard electrical outlet.
3. Turn the power on. Normally, The LED (Power) Light will turn on when electric current passes.
4. Charging starts. During charging, LED (Charge) will indicate orange light, when it turns to green light, that means well-charged.
5. LED indication
  - LED(POWER) - GREEN LIGHT ON : Power On.
  - LED(CHARGE) - ORANGE LIGHT ON : Charging / GREEN LIGHT ON : Fully Charged
6. Charger Trouble Shooting
  - (A) If LED (POWER) light is off
    - Check the input voltage (115V/230V) is the same as you adjust.
    - If light is still off, please check and repair the battery charger.
  - (B) If LED (CHARGE) light is off
    - Check to see clips connection is correct.
    - If the battery is fully charged, the LED (CHARGE) light will be off.
    - If light is still off, the battery may be defective.
  - (C) If ORANGE light can turn to GREEN
    - The battery can not be charged. Please check and recover it.
  - (D) If ORANGE light turns to GREEN immediately
    - Check to see the battery is fully charged, if not, The battery may be defective
    - Check and recover it.



The time needed to recharge will vary depending on the depletion of the batteries. Charging for longer than necessary will not harm the batteries. They can not be overcharged.

### Keep in mind these rules :

Fully charge batteries at least once a month, more if you use the scooter regularly. Charge after each trip exceeding 3 kilometers.

If storing your scooter for some time (1 month or more) make sure that the batteries are fully charged, and on returning, charge them again before using scooter.

Batteries will only give maximum performance after the scooter has been used, and the batteries have been recharged up to 10 times. A bit like running in a new car.

## CARE AND MAINTENANCE

### Cleaning Your Scooter :

If your scooter is dirty, use a damp or lightly soapy cloth to wipe it down. Do not use running water to wash or rinse the scooter in order to protect the electrical parts. Polish with an automotive liquid polish.

### Maintaining Your Scooter :

All maintenance and repair of your scooter should be done by an authorized dealer. The following areas required periodic inspection:

- Tire pressure between 30-50 lbs.
- all electrical connections are firmly attached.

### Storing Your Scooter :

Between uses, your scooter is best stored in a dry location.

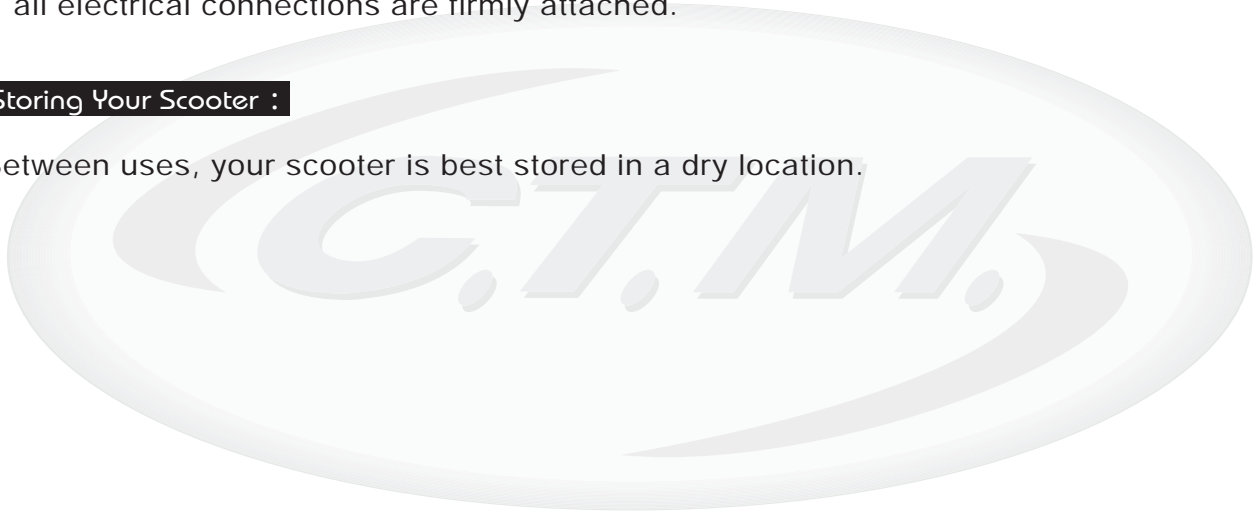

## TROUBLESHOOTING

Here are some suggestions about solving problems you may have with your scooter. There is a Self-Diagnostic Warning Light on the Control Panel. To check the Self-Diagnostic Warning Light, turn on the key and count the number of blinks on the Warning Light.

Number of Flashes	Problem	Solution
1	Battery needs recharging	Recharge the batteries soon.
2	Battery voltage too low to operate scooter	Must recharge before using. Check battery condition and connections.
3	Battery voltage too high	Check battery condition and connections. Contact your authorized dealer to check your battery charger.
4	Short in motor	Contact your authorized dealer.
5	Brake malfunction	Contact your authorized dealer.
6	Transmission lever not in neutral	Contact your authorized dealer.
7	Transmission lever Malfunction	Contact your authorized dealer.
8	Motor problems	Contact your authorized dealer.
9	Other internal errors	Contact your authorized dealer.

**Other Problems :**

Low tire pressure: pump up tires to 30-50 lbs.

During charging, the light on the charger does not change to green:  
Contact your authorized dealer.

Scooter will not move when key is turned on:

1. Check Power Reserve Indicator on the control panel. It should be lit in the green, yellow, and red zones.
2. Check Self-Diagnostic Warning Light. It should be steady. If it is flashing, see chart on page 15 for problem identification.
3. Check all electrical connections to be sure they are tight.
4. If none of these correct the problem, contact your authorized dealer.

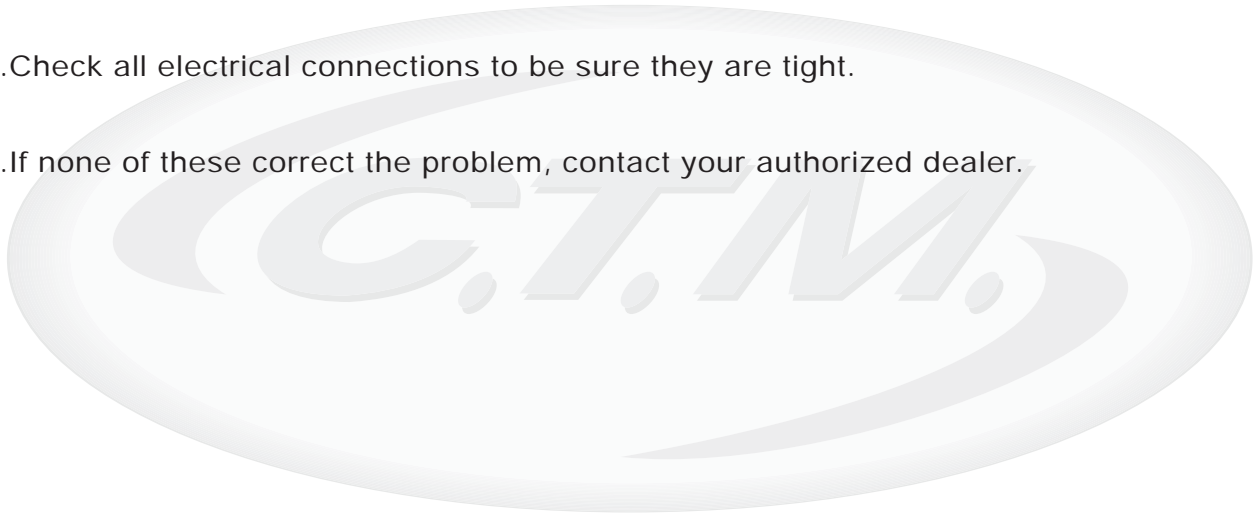

**SPECIFICATION**

SPECIFICATIONS	HS-570	HS-580
Overall Length	48.8"	50.4"
Overall Width	24"	24"
Overall Height	43.7"	43.7"
Wheels: Front	10"	10"
Wheels: Rear	10"	10"
Weight w/ Batteries	185.2 lbs	194 lbs
Max. Speed	5 mph	5 mph
Weight Capacity	300 lbs	300 lbs
Ground Clearance	1.6"	1.6"
Grade Climbable	12 degree	12 degree
Curb Climbing	2"	2"
Turning Radius	42.5"	59.8"
Suspension	N/A	N/A
Brake	Electro-Mechanical	Electro-Mechanical
Seat Type	Premium Upholstery Mid-Back w/ Headrest Swivel Seat-Sliding Adjustment	
Seat Width	18"	18"
Motor Size	500W 3400r.p.m	500W 3400r.p.m
Battery	(2) 12V . 36Ah	(2) 12V . 36Ah
Battery Weight	55 lbs	55 lbs
Travel Range	18.6 Miles	18.6 Miles
Battery Charger	5A Off Board	5A Off Board
Electronics	On / Off Key Switch, Battery Level Indicator, Speed Control Knob	On / Off Key Switch, Battery Level Indicator, Speed Control Knob

\*Subject to change without notice. (Issue A)